

Renold Synergy® is one of the most reliable roller chains on the market in terms of fatigue and wear performance. The unique pin and bushing design reduces elongation — extending wear life nearly six times longer than other chains. User-friendly features dramatically reduce maintenance, and special link plates improve fatigue performance up to 30 percent.

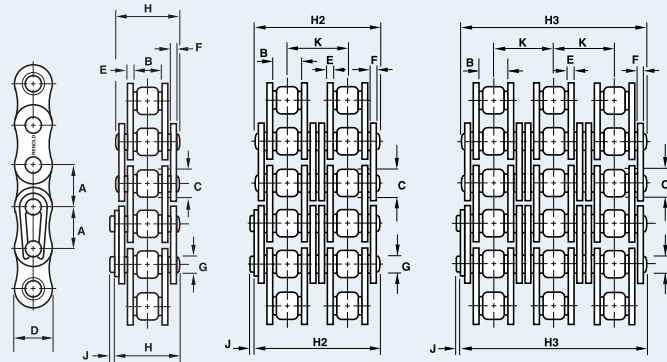

Dimensions are in inches unless otherwise indicated.

Synergy® ANSI Roller Chain

Chain No.	Renold No.	Pitch	Inside Width Min	Roller Diam Max	Plate Height Max	Inner Plate Thick Max	Outer Plate Thick Max	Pin Diam Max	Pin Length Max	Conn Link Extra Max	Trans Pitch	Tensile Strength Min	Rated Working Load	Weight
		A	B	C	D	E	F	G	H	J	K	Lbs	Lbs	Lbs/Ft
SINGLE STRAND														
*35SYN	129037	0.375	0.184	0.200	0.356	0.049	0.049	0.141	0.472	0.043	—	1,760	480	0.24
40SYN	119047	0.500	0.309	0.312	0.475	0.061	0.061	0.157	0.646	0.055	—	3,125	810	0.40
50SYN	119057	0.625	0.370	0.400	0.594	0.080	0.080	0.200	0.803	0.043	—	4,880	1,400	0.67
60SYN	119067	0.750	0.495	0.469	0.713	0.094	0.094	0.235	0.996	0.043	—	7,030	1,950	0.99
80SYN	119087	1.000	0.620	0.625	0.950	0.128	0.128	0.313	1.287	0.118	—	12,500	3,300	1.88
100SYN	119107	1.250	0.744	0.750	1.188	0.160	0.160	0.376	1.563	0.165	—	19,530	5,060	2.82
120SYN	119127	1.500	0.993	0.875	1.425	0.189	0.189	0.437	1.941	0.209	—	28,125	6,800	3.83
140SYN	119147	1.750	0.993	1.000	1.663	0.221	0.221	0.500	2.083	0.205	—	38,280	9,000	5.24
160SYN	119167	2.000	1.242	1.125	1.900	0.250	0.250	0.563	2.484	0.256	—	50,000	11,900	6.99
DOUBLE STRAND														
*35-2SYN	125037	0.375	0.184	0.200	0.356	0.049	0.049	0.141	0.874	0.043	0.399	3,520	810	0.47
40-2SYN	115047	0.500	0.309	0.312	0.475	0.061	0.061	0.157	1.213	0.055	0.566	6,250	1,370	0.81
50-2SYN	115057	0.625	0.370	0.400	0.594	0.080	0.080	0.200	1.512	0.043	0.713	9,760	2,380	1.41
60-2SYN	115067	0.750	0.495	0.469	0.713	0.094	0.094	0.235	1.894	0.043	0.897	14,060	3,315	2.05
80-2SYN	115087	1.000	0.620	0.625	0.950	0.128	0.128	0.313	2.437	0.118	1.153	25,000	5,610	3.70
100-2SYN	115107	1.250	0.744	0.750	1.188	0.160	0.160	0.376	2.968	0.165	1.408	39,060	8,600	5.64
120-2SYN	115127	1.500	0.993	0.875	1.425	0.189	0.189	0.437	3.728	0.209	1.789	56,250	11,560	7.39
140-2SYN	115147	1.750	0.993	1.000	1.663	0.221	0.221	0.500	4.008	0.205	1.924	76,560	15,300	10.41
160-2SYN	115167	2.000	1.242	1.125	1.900	0.250	0.250	0.563	4.787	0.256	2.305	100,000	20,230	13.84
TRIPLE STRAND														
*35-3SYN	127037	0.375	0.184	0.200	0.356	0.049	0.049	0.141	1.268	0.043	0.399	5,280	1,200	0.70
40-3SYN	117047	0.500	0.309	0.312	0.475	0.061	0.061	0.157	1.776	0.055	0.566	9,375	2,025	1.21
50-3SYN	117057	0.625	0.370	0.400	0.594	0.080	0.080	0.200	2.224	0.043	0.713	14,640	3,500	2.01
60-3SYN	117067	0.750	0.495	0.469	0.713	0.094	0.094	0.235	2.791	0.043	0.897	21,090	4,875	2.97
80-3SYN	117087	1.000	0.620	0.625	0.950	0.128	0.128	0.313	3.591	0.118	1.153	37,500	8,250	5.56
100-3SYN	117107	1.250	0.744	0.750	1.188	0.160	0.160	0.376	4.381	0.165	1.408	58,590	12,650	8.44
120-3SYN	117127	1.500	0.993	0.875	1.425	0.189	0.189	0.437	5.524	0.209	1.789	84,375	17,000	11.19
140-3SYN	117147	1.750	0.993	1.000	1.663	0.221	0.221	0.500	5.938	0.205	1.924	114,840	22,500	15.48
160-3SYN	117167	2.000	1.242	1.125	1.900	0.250	0.250	0.563	7.100	0.256	2.305	150,000	29,750	20.77

* Rollerless Chain

† Renold Synergy® far exceeds the ISO606 minimum tensile strength requirement, but Renold does not consider this a useful indicator of the key chain performance areas: wear and fatigue.

Synergy® Chain

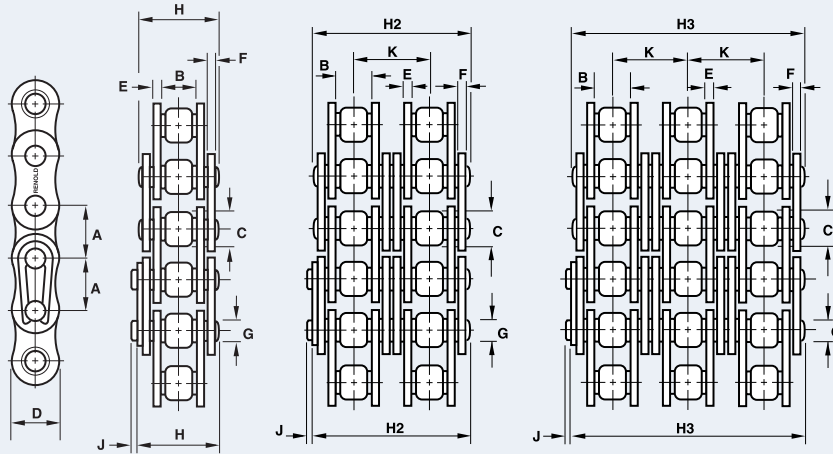

Synergy® British Standard roller chain is made in accordance with ISO 606 B, BS 228, and DIN 8187 European standards. These chains resemble standard Synergy® ANSI roller chains, but are dimensionally different and in general do NOT operate over standard ANSI sprockets. Synergy® British Standard roller chains are made with the same unique bushings and rollers and incorporate all the design advantages of Synergy® ANSI chains.

Synergy® British Standard Roller Chain

Dimensions are in inches unless otherwise indicated.

Chain No.	Renold No.	Pitch	Inside Width Min	Roller Diam Max	Plate Height Max	Inner Plate Thick Max	Outer Plate Thick Max	Pin Diam Max	Pin Length Max	Conn Link Extra Max	Trans Pitch	Tensile Strength Min	Rated Working Load	Weight
		A	B	C	D	E	F	G	H	J	K	Lbs	Lbs	Lbs/Ft
SINGLE STRAND														
06BSYN	110038	0.375	0.225	0.250	0.325	0.051	0.041	0.129	0.492	0.051	—	2,001	395	0.26
08BSYN	110046	0.500	0.305	0.335	0.465	0.061	0.061	0.175	0.669	0.059	—	4,002	700	0.47
10BSYN	110056	0.625	0.380	0.400	0.580	0.061	0.061	0.200	0.740	0.051	—	4,991	1,100	0.62
12BSYN	110066	0.750	0.460	0.475	0.635	0.071	0.071	0.225	0.862	0.043	—	6,497	1,575	0.81
16BSYN	110088	1.000	0.670	0.625	0.830	0.162	0.122	0.326	1.374	0.087	—	13,489	2,810	1.88
20BSYN	110106	1.250	0.770	0.750	1.040	0.182	0.142	0.401	1.569	0.106	—	21,357	4,370	2.59
24BSYN	110127	1.500	1.000	1.000	1.315	0.240	0.200	0.576	2.071	0.268	—	35,970	6,130	5.01
DOUBLE STRAND														
06B-2SYN	114038	0.375	0.225	0.250	0.325	0.051	0.041	0.129	0.906	0.051	0.403	3,800	670	0.50
08B-2SYN	114046	0.500	0.305	0.335	0.465	0.061	0.061	0.175	1.197	0.059	0.548	6,992	1,185	0.93
10B-2SYN	114056	0.625	0.380	0.400	0.580	0.061	0.061	0.200	1.394	0.051	0.653	10,004	1,870	1.21
12B-2SYN	114066	0.750	0.460	0.475	0.635	0.071	0.071	0.225	1.630	0.043	0.766	12,994	2,680	1.61
16B-2SYN	114088	1.000	0.670	0.625	0.830	0.162	0.122	0.326	2.630	0.087	1.255	23,830	4,780	3.69
20B-2SYN	114106	1.250	0.770	0.750	1.040	0.182	0.142	0.401	3.020	0.106	1.435	38,218	7,430	5.23
24B-2SYN	114127	1.500	1.000	1.000	1.315	0.240	0.200	0.576	3.988	0.268	1.904	62,946	10,270	9.92
TRIPLE STRAND														
06B-3SYN	116038	0.375	0.225	0.250	0.325	0.051	0.041	0.129	1.312	0.051	0.403	5,598	1,000	0.74
08B-3SYN	116046	0.500	0.305	0.335	0.465	0.061	0.061	0.175	1.745	0.059	0.548	10,004	1,750	1.38
10B-3SYN	116056	0.625	0.380	0.400	0.580	0.061	0.061	0.200	2.049	0.051	0.653	14,995	2,750	1.70
12B-3SYN	116066	0.750	0.460	0.475	0.635	0.071	0.071	0.225	2.399	0.043	0.766	19,491	3,930	2.41
16B-3SYN	116088	1.000	0.670	0.625	0.830	0.162	0.122	0.326	3.885	0.087	1.255	35,969	7,025	5.46
20B-3SYN	116106	1.250	0.770	0.750	1.040	0.182	0.142	0.401	4.460	0.106	1.435	56,202	10,925	7.81
24B-3SYN	116127	1.500	1.000	1.000	1.315	0.240	0.200	0.576	5.898	0.268	1.904	95,544	15,100	14.91