

Engineering Class 81X Conveyor Chain

Dimensions are in inches unless otherwise indicated.

Chain No.	Pitch	Inner Width Max	Roller Diam Max	Plate Height Max	Inner Plate Thick Max	Outer Plate Thick Max	Pin Diam Max	Pin Length Max	Average Ultimate Strength	Rated Working Load	Weight
	A	B	C	D	E	F	G	H	Lbs	Lbs	Lbs/Ft
81X	2.609	1.062	0.906	1.125	0.156	0.156	0.438	2.078	25,000	*	2.40
81XH	2.609	1.062	0.906	1.265	0.313	0.219	0.438	2.531	40,000	*	3.50
81XHH	2.609	1.062	0.906	1.265	0.313	0.219	0.438	1.265	42,000	*	4.60

*Contact Renold Jeffrey for Rated Working Loads.

21 Forestry Chain

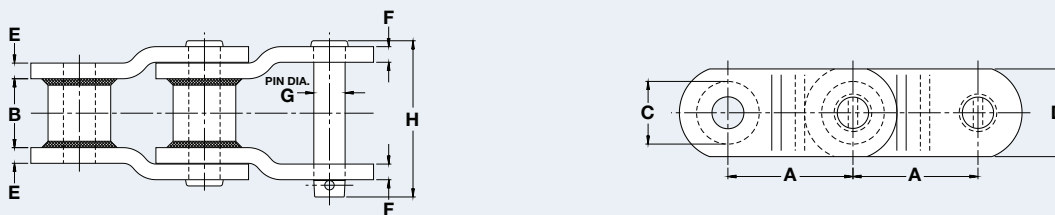

Engineering Class Welded Steel Mill Chain

Dimensions are in inches unless otherwise indicated.

Chain No.	Pitch	Inner Width Max	Barrel Diam Max	Plate Height Max	Plate Thick Max	Pin Diam Max	Pin Length Max	Average Ultimate Strength	Rated Working Load	Weight
	A	B	C	D	E/F	G	H	Lbs	Lbs	Lbs/Ft
WS78	2.609	1.500	0.875	1.125	0.250	0.500	3.000	24,000	3,000	3.90
WS78P								30,000	3,500	
WS82	3.075	1.750	1.219	1.250	0.250	0.563	3.219	26,000	3,750	5.50
WS82P								35,000	4,400	
WS82H	3.075	1.750	1.219	1.250	0.375	0.563	3.719	26,000	4,600	7.10
WS82HP								35,000	5,400	
WS784	4.000	1.500	0.875	1.125	0.250	0.500	2.953	24,000	3,000	3.30
WS784P								30,000	3,500	
WS124	4.000	2.060	1.438	1.500	0.375	0.750	4.220	46,000	6,300	8.50
WS124P								60,000	7,350	
WS124HD	4.063	2.000	1.625	2.000	0.500	0.875	4.672	84,000	7,850	14.40
WS124HDP								90,000	9,150	
WS111	4.760	2.625	1.438	1.500	0.375	0.750	4.750	46,000	7,550	8.40
WS111P								58,600	8,850	
WS106	6.000	2.063	1.375	1.500	0.375	0.750	4.187	37,000	6,300	6.70
WS106P								56,500	7,400	
WS110	6.000	2.250	1.250	1.500	0.375	0.750	4.375	46,000	6,750	6.60
WS110P								60,000	7,850	
WS132	6.050	3.375	1.750	2.000	0.500	1.000	6.172	84,000	13,100	13.50
WS132P								100,000	15,300	
WS150	6.050	3.375	1.750	2.500	0.500	1.000	6.172	84,000	13,100	14.50
WS150P								100,000	14,500	
WS855PB	6.050	3.313	1.750	2.500	0.563	1.125	6.563	150,000	17,000	20.50
WS855HDP	6.050	3.375	1.750	2.500	0.625	1.125	6.875	175,000	20,000	20.50
WS859PB	6.125	3.375	2.000	3.000	0.625	1.250	6.938	230,000	20,250	23.50

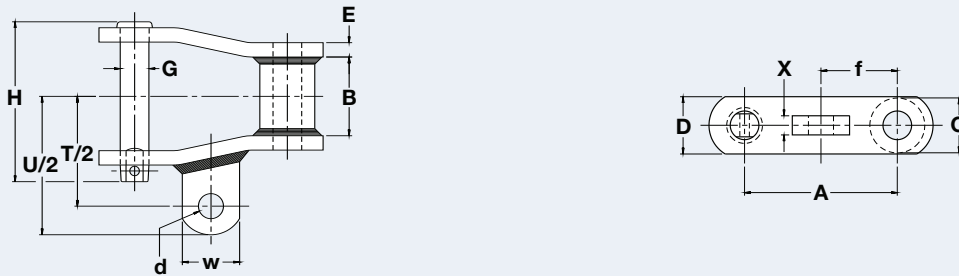

A-42 Welded Steel Mill Chain Attachments

Dimensions are in inches unless otherwise indicated.

Chain No.	A	B	C	D	E	G	H	T/2	U/2	X	d	f	w
WS78	2.609	1.125	0.875	1.125	0.250	0.500	3.000	2.250	2.875	0.500	0.656	1.438	1.500
WS82	3.075	1.250	1.219	1.250	0.250	0.563	3.219	2.500	3.125	0.375	0.563	1.531	1.500
WS124	4.000	1.625	1.438	1.500	0.375	0.750	4.188	2.875	3.625	0.500	0.656	2.000	1.500
WS110	6.000	1.875	1.250	1.500	0.375	0.750	4.375	2.563	3.141	0.406	0.500	2.250	1.500
WS150	6.050	2.875	1.750	2.500	0.500	1.000	6.172	4.000	4.938	0.500	0.656	2.656	2.000

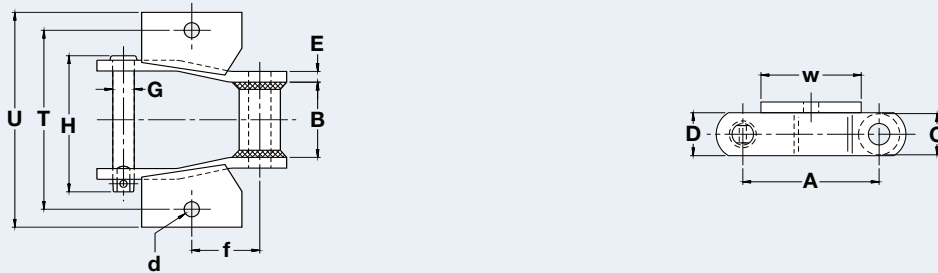

K-1 Welded Steel Mill Chain Attachments

Dimensions are in inches unless otherwise indicated.

Chain No.	A	B	C	D	E	G	H	T	U	d	f	w
WS78	2.609	1.125	0.875	1.125	0.250	0.500	3.000	4.000	5.000	0.375	1.344	2.000
WS82	3.075	1.250	1.219	1.250	0.250	0.563	3.219	4.250	5.500	0.375	1.578	1.750
WS124	4.000	1.625	1.438	1.500	0.375	0.750	4.188	5.250	6.375	0.625	2.188	2.000
WS111	4.760	2.250	1.438	1.500	0.375	0.750	4.750	6.250	7.500	0.500	2.375	3.500

Contact Renold Jeffrey for weight specifications and for verification as dimensions are subject to change.

Forestry Chain

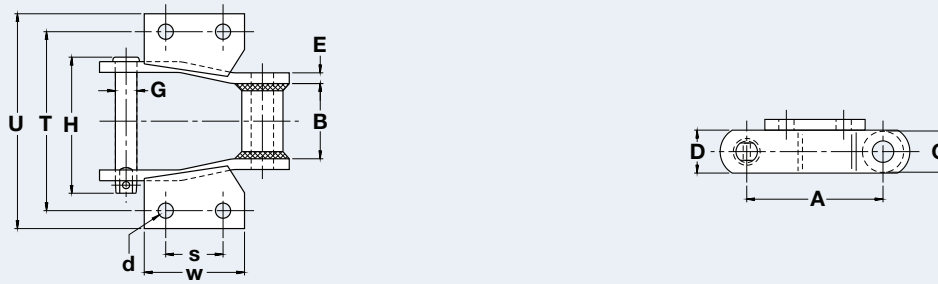

K-2 Welded Steel Mill Chain Attachments

Dimensions are in inches unless otherwise indicated.

Chain No.	A	B	C	D	E	G	H	T	U	d	s	w
WS78	2.609	1.125	0.875	1.125	0.250	0.500	3.000	4.000	5.000	0.375	1.125	2.000
WS82	3.075	1.250	1.219	1.250	0.250	0.563	3.219	4.250	5.500	0.375	1.313	2.875
WS124	4.000	1.625	1.438	1.500	0.375	0.750	4.188	5.250	6.375	0.375	1.938	3.000
WS111	4.760	2.250	1.438	1.500	0.375	0.750	4.750	6.250	7.500	0.500	2.313	3.500
WS110	6.000	1.875	1.250	1.500	0.375	0.750	4.375	5.313	7.188	0.375	1.750	3.250
WS132	6.050	2.875	1.750	2.000	0.500	1.000	6.172	7.500	9.125	0.500	2.750	4.000
WS150	6.050	2.875	1.750	2.500	0.500	1.000	6.172	7.500	9.125	0.531	2.750	4.000

Contact Renold Jeffrey for weight specifications and for verification as dimensions are subject to change.

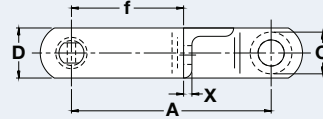
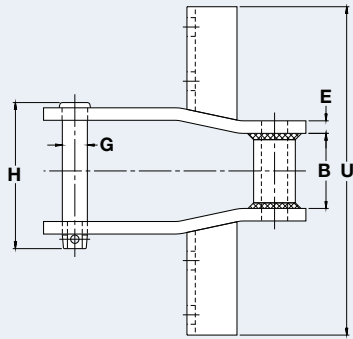

Welded Steel Mill Chain Wing Attachments

Dimensions are in inches unless otherwise indicated.

Chain No.	A	B	C	D	E	G	H	U	X	f
WS78	2.609	1.125	0.875	1.125	0.250	0.500	3.000	6.000	0.250	0.750
WS82	3.075	1.250	1.219	1.250	0.250	0.563	3.219	6.500	0.250	0.750
WS124	4.000	1.625	1.438	1.500	0.375	0.750	4.188	8.500	0.250	1.188
WS132	6.050	2.875	1.750	2.000	0.500	1.000	6.172	12.375	0.500	1.500

Contact Renold Jeffrey for weight specifications and for verification as dimensions are subject to change.

Forestry Chain

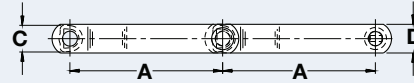
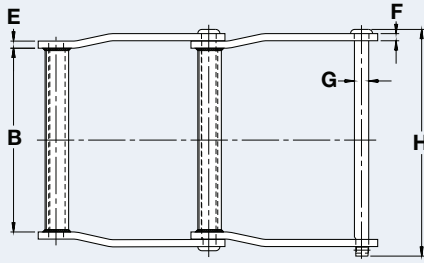

Engineering Class Welded Steel Drag Chain

Dimensions are in inches unless otherwise indicated.

Chain No.	Pitch	Inner Width Max	Barrel Diam Max	Plate Height Max	Plate Thick Max	Pin Diam Max	Pin Length Max	Average Ultimate Strength	Rated Working Load	Weight
	A	B	C	D	E/F	G	H	Lbs	Lbs	Lbs/Ft
WSD102	5.000	7.000	1.500	1.500	0.375	0.750	9.250	42,000	7,000	12.00
WSD102P								60,000	10,000	
WSD104	6.000	4.625	1.500	1.500	0.375	0.750	6.891	46,000	7,650	8.60
WSD104P								60,000	10,000	
WSD110	6.000	9.625	1.500	1.500	0.375	0.750	11.875	46,000	7,650	13.50
WSD110P								60,000	10,000	
WSD120	6.000	9.250	2.000	2.000	0.500	0.875	12.063	70,000	11,500	22.00
WSD120P								90,000	15,000	
WSD112	8.000	9.625	1.500	1.500	0.375	0.750	11.875	46,000	7,650	11.40
WSD112P								60,000	10,000	
WSD116	8.000	13.375	1.750	1.750	0.375	0.750	15.625	56,000	9,300	16.00
WSD116P								69,000	11,500	
WSD122	8.000	9.250	2.000	2.000	0.500	0.875	12.063	70,000	11,500	18.00
WSD122P								90,000	15,000	
WSD480	8.000	11.750	2.000	2.000	0.500	0.875	14.563	84,000	14,000	20.00
WSD480P								90,000	15,000	
WD480XHDP	8.000	11.750	2.000	2.000	0.625	1.000	15.160	122,000	20,300	21.00

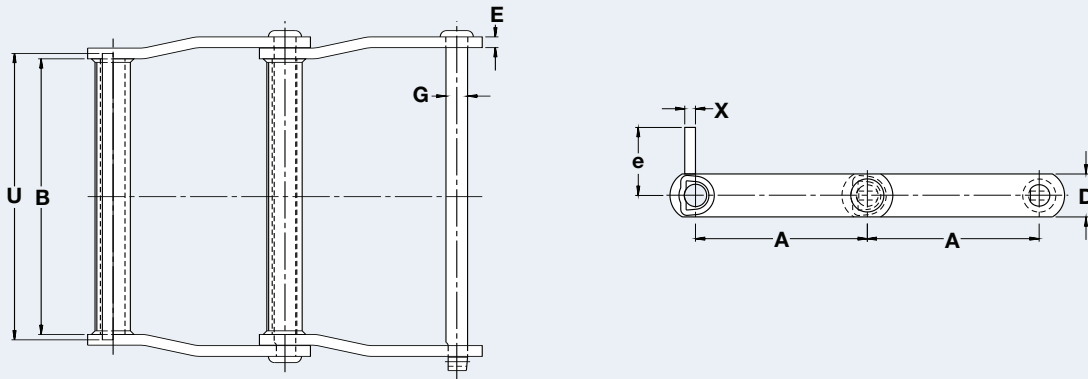

C-Style Welded Steel Drag Chain Attachments

Dimensions are in inches unless otherwise indicated.

Chain No.	Att. Type	A	B	D	E	G	U	X	e
WSD102	C-1	5.000	6.375	1.500	0.375	0.750	7.000	0.375	2.375
WSD104		6.000	4.125	1.500	0.375	0.750	5.000	0.375	2.375
WSD110		6.000	9.000	1.500	0.375	0.750	10.000	0.375	2.375
WSD112		8.000	9.000	1.500	0.375	0.750	10.000	0.375	2.375
WSD116		8.000	13.000	1.750	0.375	0.750	13.000	0.375	2.625
WSD122		8.000	8.750	2.000	0.500	0.875	10.000	0.500	2.000
WSD110	C-3	6.000	9.000	1.500	0.375	0.750	10.000	0.500	2.250
WSD480		8.000	11.125	2.000	0.500	0.875	14.000	0.500	3.000
WSD102	C-4	5.000	6.375	1.500	0.375	0.750	7.000	0.375	3.750
WSD104		6.000	4.125	1.500	0.375	0.750	5.000	0.375	3.750
WSD110		6.000	9.000	1.500	0.375	0.750	10.000	0.375	3.750
WSD112		8.000	9.000	1.500	0.375	0.750	10.000	0.375	3.750
WSD116		8.000	13.000	1.750	0.375	0.750	13.000	0.375	4.813
WSD480		8.000	11.125	2.000	0.500	0.875	14.000	0.500	5.000

Contact Renold Jeffrey for weight specifications and for verification as dimensions are subject to change.

Forestry Chain

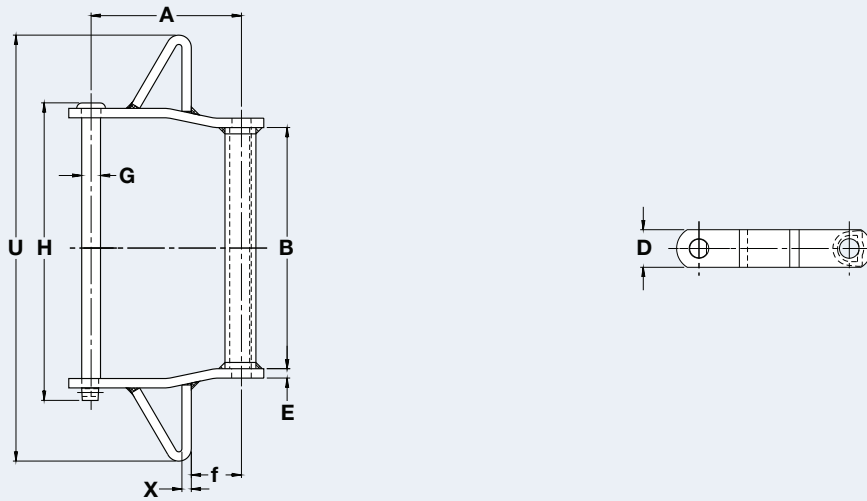

Welded Steel Drag Chain Wing Attachments

Dimensions are in inches unless otherwise indicated.

Chain No.	A	B	D	E	G	H	U	X	f
WSD102	5.000	6.375	1.500	0.375	0.750	9.250	14.250	0.375	2.000
WSD104	6.000	4.125	1.500	0.375	0.750	6.875	11.500	0.375	2.250
WSD110	6.000	9.000	1.500	0.375	0.750	11.875	17.000	0.375	2.250
WSD112	8.000	9.000	1.500	0.375	0.750	11.875	17.000	0.375	2.250
WSD116	8.000	13.000	1.750	0.375	0.750	15.625	22.031	0.375	2.500
WSD480	8.000	11.125	2.000	0.500	0.875	14.563	22.000	0.500	2.500

Contact Renold Jeffrey for weight specifications and for verification as dimensions are subject to change.